

Battery-free Sensing Platform for Wearable Devices: The Synergy Between Two Feet

Qianyi Huang*, Yan Mei*, Wei Wang^{†‡} and Qian Zhang*

* Department of Computer Science and Engineering, and [‡] Guangzhou Fok Ying Tung Research Institute, Hong Kong University of Science and Technology

[†] School of Electronic Information and Communications, Huazhong University of Science and Technology
Email: {qhuangaa, ymeiab, gswwang, qianzh}@ust.hk

Abstract—Recent years have witnessed the prevalence of wearable devices. Wearable devices are intelligent and multifunctional, but they rely heavily on batteries. This greatly limits their application scope, where replacement of battery or recharging is challenging or inconvenient. We note that wearable devices have the opportunity to harvest energy from human motion, as they are worn by the people as long as being functioning. In this study, we propose a battery-free sensing platform for wearable devices in the form-factor of shoes. It harvests the kinetic energy from walking or running to supply devices with power for sensing, processing and wireless communication, covering all the functionalities of commercial wearable devices. We achieve this goal by enabling the whole system running on the harvested energy from two feet. Each foot performs separate tasks and two feet are coordinated by ambient backscatter communication. We instantiate this idea by building a prototype, containing energy harvesting insoles, power management circuits and ambient backscatter module. Evaluation results demonstrate that the system can wake up shortly after several seconds' walk and have sufficient Bluetooth throughput for supporting many applications. We believe that our framework can stir a lot of useful applications that were infeasible previously.

I. INTRODUCTION

Wearable devices are penetrating into our daily life. They are playing important roles in a lot of applications. Wearable health kits provide health-care for the elderly people who are living alone, and give out alerts to doctors or family members when detecting abnormal physiology. Wearable devices may also provide cognitive-assistance for those in cognitive decline. People who suffer cognitive decline have difficulties performing some basic functions. Wearable gadgets, such as Google Glass [15], can help them with cognitive tasks, such as face recognition and speech recognition.

Wearable devices rely on the battery for providing power for sensing, processing, and communication with smartphone or cloud server. The majority of wearable devices require frequent charging. For example, the famous heart rate wristband, Mio [7], can only supply up to 20 hours' continuous heart rate monitoring. Frequent recharging is a challenging requirement in the above mentioned scenarios. Elderly people easily forget to recharge their health kits. The situation is even more challenging for those in cognitive decline, who may be already suffering from memory loss. This requirement hinders the original intention for the wearable devices to be unobtrusive.

A vision for wearable devices is to be battery-free. Existing battery-free devices harvest energy from different sources, including solar energy, RF signals (*e.g.*, [13], [18]), ambient heat source or temperature changes (*e.g.*, [32]). They are limited to specific environments, which require sunlight, heat

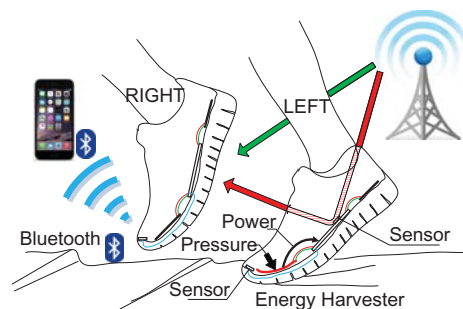

Fig. 1. System overview.

sources or a powerful RF reader for battery-free RFID tags. These conditions can not be satisfied by wearable devices, as users may wear them and go around. Different from wireless sensor nodes, wearable devices are worn by users for long periods of time, which brings the feasibility that wearable devices can be energy self-sufficiency, by harvesting energy from human body.

In our study, we design a battery-free sensing platform for wearable devices in the form-factor of shoes. Although there are many possible designs to harness energy from human body [14], we choose harvesting kinetic energy during walking/running for four reasons. First, there is promising amount of kinetic energy available during walking or running; second, shoes are worn by users for the majority of daily time, including the time spent in the office/school, wandering on the street, and going on a visit to a park or a supermarket; third, wearable devices coming in the form-factor of shoes are gaining popularity. Shoes play important roles in many aspects, such as assuring pedestrian safety [17], navigation (*e.g.*, Lechal [4]) and fitness tracking (*e.g.*, Nike+ [9]); the last but not least reason is attributed to the simple behaviour pattern of feet. The most prevailing form-factor of wearable devices is wristband. However, our hands perform a lot of complicated activities, which make it difficult for activity recognition and health monitoring. The simple behaviour pattern of the feet, either resting on the floor or lift in the air during walking and running, can improve the accuracy for a lot of applications (*e.g.*, pedometers). Provided that there are existing commercial wearable products coming in the form-factor of shoes (*e.g.*, Nike+, Lechal), we believe that shoes are appropriate for mounting sensors.

Although the idea sounds favourable, we encounter several challenges. Given a number of existing works on energy

harvesting shoes, we note that there is a gap between existing studies and our goal. Existing works on energy harvesting shoes can generate about 1 – 2 mW [16], [19], [26], [33]. This amount is insufficient for some power-hungry sensing hardware (*e.g.*, inertial measurement unit) and wireless communication module (*e.g.*, Bluetooth). We further note that existing works can only utilize the energy harvested from one foot. During walking or running, our two feet can generate almost equal amount of energy. Yet there is no existing feasible solution to combine these two parts of available energy to support a complete sensing system.

It is not trivial to enable the whole system running with the energy from two feet. The most straightforward solution is to transfer the energy from one foot to the other foot. It is obvious that adding a solid wire to transfer the charge is not practical. Wireless power transfer is also infeasible with the tiny amount of harvested energy, not to mention the distance between two feet when stepping out.

Since power transfer is infeasible, we come up with the idea of enabling a data channel between two feet to coordinate these two distributed parts. Traditional communication methods (*e.g.*, Bluetooth, WiFi) consume at least tens of milliwatts, which are too costly in our scenario. Instead, we choose ambient backscatter [21], [22]. It does not actively generate radio waves, but works by backscattering existing RF signals in the air, which consumes almost zero energy. Thus, the two feet communicate by ambient backscatter at nearly zero cost. The data channel combines these two distributed parts, and thus they can work together and each of them contributes its harvested energy to the whole system.

However, ambient backscatter suffers high packet error rate during motion. Ambient backscatter transmits data at low rates (*i.e.*, 100bps-10kbps). It can take up to two seconds to send a 256-byte packet [22]. Moving at a normal speed (*e.g.*, 1 Hz per foot) will cause changes within that time frame. Consequently, packet error rate increases significantly over static scenarios. Furthermore, the error rate is dependent on the moving speed, stride length and ambient environment. The error rate fluctuates significantly, thus the error control methods should dynamically adjust the trade-off between redundancy and error-correcting capability. To address these challenges, we borrow the idea from rateless codes. When moving, the distance and orientation between two feet keep changing. The receiver has higher probability to successfully receive small chunks of data instead of complete packets. Instead of transmitting a complete packet, data are divided into several small chunks. Each time the transmitter transmits a combination of these chunks. The transmitter keeps sending such chunks until the receiver acknowledges successful reception. The receiver can recover the original packet as long as it receives enough number of different chunks, even though some of the transmissions may fail. As we mentioned before, ambient backscatter is almost energy free, thus redundant transmission would not consume much energy.

In our design, we allocate separate tasks to each foot. As shown in Figure 1, two feet have different hardware. One foot is equipped with sensing hardware (*e.g.*, accelerometer, pulse sensor, temperature sensor). It senses user activity or ambient environment, and informs the other foot of the results by ambient backscatter. The other foot can transmit this information wirelessly to users’ smartphone. In this way, we fully utilize the harvested energy on both feet.

Our platform is targeted for applications that are functioning only when the user is moving, such as location tracking devices and pedometers. We demonstrate our sensing platform as a pedometer. The evaluation results show that our system can wake up after 9 seconds’ walking. It can transmit about 48-byte data every minute via Bluetooth when walking and 60 bytes every 48 seconds when jogging. The rateless mechanism can guarantee reliable data transmission in both indoor and outdoor scenarios. This system is also compatible with other sensors, such as pulse sensor and temperature sensor. For more discussion on supporting applications, please refer to Section VIII.

We summarize our main contributions as follows:

- 1) We design a battery-free sensing platform for wearable devices, in the form-factor of shoes. It provides all the functionality of commercial wearable devices, including sensing, processing and wireless communication.
- 2) We are the first to enable the whole system running on the energy harvested from two feet, leveraging ambient RF signals. We design a rateless transmission mechanism according to the moving pattern of feet, which guarantees reliable data transmission and reduces transmission overheads.
- 3) We demonstrate our system as a pedometer and conduct extensive experiments to evaluate our design in real-life scenarios. Evaluation results demonstrate the feasibility that wearable devices can be completely battery-free.

II. DESIGN RATIONALE

A. Only one feet is insufficient

Existing works design different kinds of energy harvesting shoes, either by shoe-mounted rotary magnetic generator [19] or piezoelectric shoes [19], [33]. In this paper, we limit our scope to piezoelectric shoes, for they can be easily incorporated into a sole structure. Confined by many design considerations (*e.g.*, user comfort, weight, size), state-of-the-art piezoelectric shoes can generate about 1-2 mW energy [16], [19], [26], [33].

In Table I, we list the energy consumption for different components of wearable devices, including sensors, micro-controllers and communication module. From Table I, we can see that the power consumption for the micro-controllers is at a relatively low level, while sensors (*e.g.*, pulse sensor and inertial measurement unit) and wireless communication modules consume much more energy. This amount is beyond what is available from energy harvesting shoes.

TABLE I
ENERGY CONSUMPTION.

Category	Component	Power consumption
MCU	MSP430 series [8]	220 μ A @ 1MIPS, 3V
	EFM32 series [3]	114 μ A @ 1MHz, 3V
Sensors	Pulse Sensor [11]	4mA @ 5V
	Inertial Unit [6]	3.4mA @ 1.8V
Communication	Bluetooth [2]	4.9 mA @ 0 dBm, 3V
	ZigBee [1]	6.1 mA @ 0 dBm, 3V
	WiFi [10]	19 mA @ 1Mbps, 3.3V

Furthermore, storing increasing amounts of energy is exponentially hard. In our scenario, the energy source is only intermittently available when the feet hit ground. For the majority of time, storage capacitor is in self-discharge (leakage) state. Leakage current increases exponentially with stored

voltage [28]. This leakage effect is particularly severe with supercapacitor, where rated voltage is low (*e.g.*, 2-3V).

On one hand, we are starving for energy; on the other hand, we only count on the energy harvested from one foot, leaving the energy on the other foot unused. If we could combine these two parts of energy, we could double the total available energy for our wearable devices. Besides, we could separate the energy storage to two feet. It is a pity that there are no existing efforts devoted to bridge this gap.

B. Ambient backscatter can bridge the gap between two feet

To solve the aforementioned challenge, one solution is to use wireless power transfer to transfer the energy from one foot to the other foot. However, this solution is not feasible in our scenario. First, in wireless power transfer, it requires a powerful transmitter to generate an oscillating electromagnetic field. This requirement cannot be satisfied in this energy harvesting scenario. The harvested energy is too trivial to generate the oscillating electromagnetic field. Second, the wireless power transfer efficiency drops exponentially with increasing distances. Commercial wireless phone chargers work in distances of one or a few centimeters. During walking, the distance between two feet can be as large as tens of centimeters. All these factors hold back the adoption of wireless power transfer techniques in our study.

Although it is infeasible to transfer energy from one foot to the other foot, instead, it is possible to transfer information between two feet. We come up with a solution to establish a data channel between two feet. The data channel could be used to coordinate the two distributed systems on two separate feet. Thus the two parts can make a whole system.

The data channel must come at a cheap price in terms of energy consumption. Traditional communication methods, such as WiFi, Bluetooth, or Zigbee, cannot work in such an ultra-low power system, for they consume at least tens of milliwatts. Instead, we choose ambient backscatter communication [21], [22]. Different from the traditional radio communication, ambient backscatter does not generate radio signals, which is very power consuming. Instead, the transmitter modulates existing signals in the air for near field communication, and the receiver uses only analog components for decoding. It only consumes several microwatts. Ambient backscatter working at 539MHz can communicate over a distance of 75 cm [21], which is enough for data transmission between two feet.

III. SYSTEM OVERVIEW

A. Design goal

The goal of this study is to enable wearable devices to function normally without battery. To be specific, it should provide:

- *short startup time.* The system should start up shortly after the user start walking.
- *stability.* The system should be stable during walking periods. It should avoid frequent brownout when the user comes to a short pause, such as wait for the elevator or line up in a queue.
- *proper functionality of sensors,* which depends on application scenario. It may be monitoring heart rate once per minute, or log the steps taken by the user, etc.
- *sufficient Bluetooth throughput,* which is also application-dependent. For the two above-mentioned applications,

they may need to synchronize with users' smartphone once per minute, with heart rate or step counts as payload.

For the rest of the paper, we demonstrate the system as a pedometer.

B. Design Overview

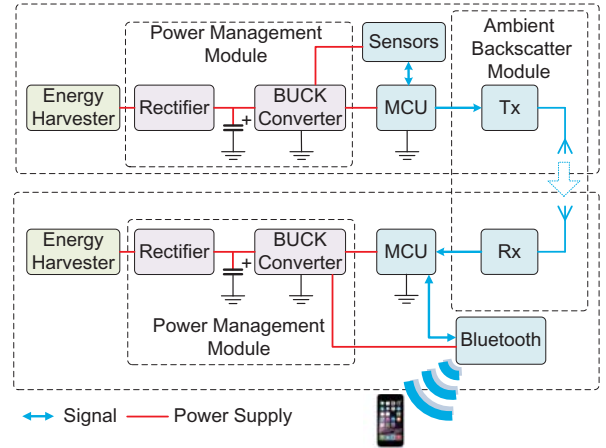

Fig. 2. System architecture.

Figure 2 shows the overview of our design. We have two energy harvesting insoles which can convert the foot pressure into electrical current, as shown in Figure 3. The electricity is rectified and stored at an input capacitor. When we walk for several steps and the voltage on the input capacitor accumulates to the threshold for waking up the power management module, the buck converter starts converting the voltage on the input capacitor into regulated voltage for supplying loads.

Each foot is responsible for separate tasks. In our design, we let one foot perform sensing and processing, and let the other foot carry out wireless communication (*i.e.*, Bluetooth) with nearby smartphones. We select Bluetooth for it is supported by the majority of commercial wearable devices. Both feet have ultra low-power micro-controllers. The micro-controller, on the foot with sensors, buffers the sensor data, does data processing and transmits the results (*e.g.*, how many steps taken so far, instantaneous heart rate) to the other foot by ambient backscatter communication. The other foot receives the information and sends it out to the users' smartphones.

Thus, we enable the end-to-end functionality of wearable devices in a battery-free scenario.

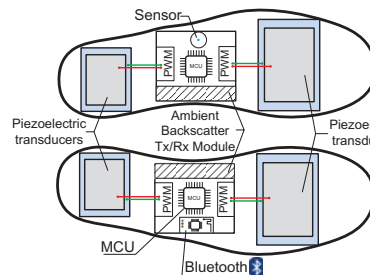

Fig. 3. Components on two shoes.

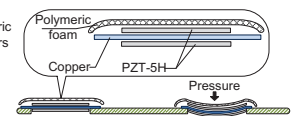

Fig. 4. Energy harvesting Insole.

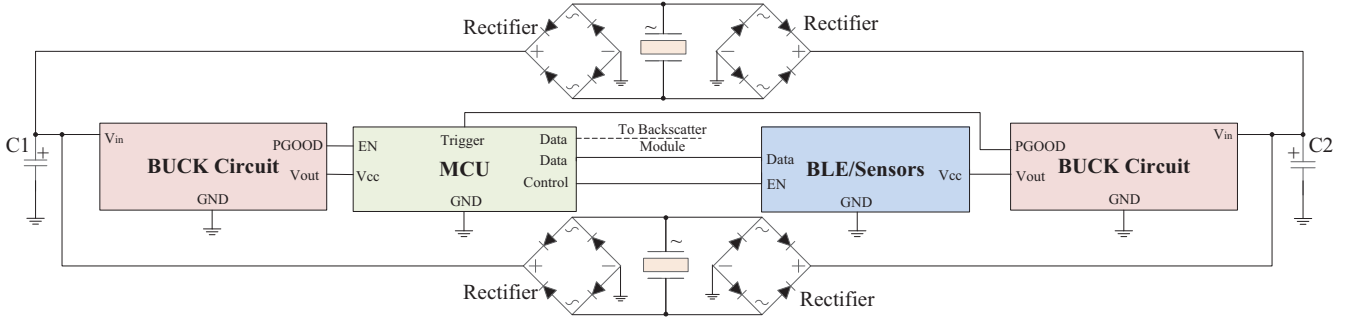

Fig. 5. Circuit diagram.

IV. INSOLE AND CIRCUIT DESIGN

In this section, we show the design details of the energy harvesting insole and power management circuits.

A. Energy Harvesting Insole

We observe that during walking, there are two phases when the insole is under high pressure. An obvious one is the contact phase when the heel hit the ground. The other one is the propulsive phase, when the heel is off the ground and body weight is on the forefoot area. Thus, we mount piezoelectric materials in these two areas to convert pressure into electricity.

As shown in Figure 4, we drill two $5\text{cm} \times 5\text{cm}$ holes on a 3mm thick PVC plate, to mount PZT-5H bimorphs. When under pressure, PZTs flex and generate electric charge. We add a thin lay of polymeric foam over the PZTs to buffer the strike process, which also contributes to user comfort. The whole insole is 4mm thick and feels as comfortable as a normal insole.

B. Power Management Circuits

The power management circuits are used to transfer the unstable and alternating voltage generated from piezoelectric transducers into stable DC voltage. The circuit diagram is shown in Figure 5.

The two piezoelectric transducers in Figure 4 are connected in parallel, for we want more current instead of higher voltage. As they are not actuated simultaneously when stepping, we use separate full-wave bridge rectifiers to prevent them from canceling each other's generated voltage. The rectified charge is stored on input capacitors. The input capacitors are selected according to the load requirements. In general, it should satisfy

$$P_L \cdot t_L \leq \frac{1}{2} \cdot \eta \cdot C_{IN} \cdot (V_{IN}^2 - V_{TH}^2).$$

Here, the left hand side is the amount of energy required by loads. V_{IN} is the voltage on the input capacitor and V_{TH} is the shunt off voltage threshold for the buck converter. η is the efficiency of buck converter. The input capacitor should store enough energy for the loads before the buck converter shunts off. This could be achieved by adjusting the value of C_{IN} or letting V_{IN} charge to a high voltage.

As shown in Figure 5, we use separate input capacitors and buck converters for micro-controller and sensors/Bluetooth. The full-wave bridges provide isolation for each input capacitor, thus they can prevent some power-hungry sensors or Bluetooth from draining away the energy for micro-controllers. Another advantage of such design is that it enables intended

power supplying sequence. For example, the micro-controller will wake up shortly after several steps, whereas it takes much longer to store enough power for Bluetooth. When the micro-controller wakes up, it consumes the energy from C_1 , thus the voltage on C_1 will fall. For the two capacitors are connected in parallel, the current from piezoelectric transducers will be directed to this lower voltage capacitor, until both V_{IN} are equal again. Thus, we can guarantee stable power supply for micro-controllers.

V. AMBIENT BACKSCATTER BETWEEN TWO FEET

We choose ambient backscatter to coordinate two feet for it consumes almost zero power. Instead of generating radio signals, ambient backscatter works by modulating existing RF (e.g., TV, WiFi) signals in the air. To transmit a string of '0's and '1's, the transmitter switches between reflecting and non-reflecting states, by switching the input impedance of the antenna in matched or mismatched states. In non-reflecting state, the receiver will only see the ambient signals; in reflecting state, the additional reflected wave from the transmitter will superimpose the original ambient signals and create changes in signal envelop. Thus, the receiver can distinguish these two states to decode the information. As there is no need for power consuming RF oscillators and high-speed ADCs, it consumes almost zero power.

For ambient backscatter to work on a pair of shoes which users would wear and walk around, we identify two unique challenges.

A. Challenges

The first challenge results from motion. As mentioned before, the reflected wave would create changes in signal envelop. The reflected wave may either constructively or destructively superimpose on the ambient signals, which depends on the relative position of the transmitter and the receiver. During walking, the distance and orientation between the two feet keep changing. For one instant, the reflecting state at the transmitter side may correspond to a large signal amplitude at the receiver side; for the next instant, it may correspond to a small signal amplitude. When such transition happens during a packet transmission, errors are inevitable even with differential coding. To make the situation worse, ambient backscatter works at a low data rate (e.g., 1 kbps). It requires more than 500 ms to send a 64 byte packet. When walking at a normal speed, say, 1 Hz per foot, channel conditions change dramatically within the span of a packet transmission. Thus, compared with static scenarios, packet error rate between a pair of moving transmitter and receiver is significantly higher.

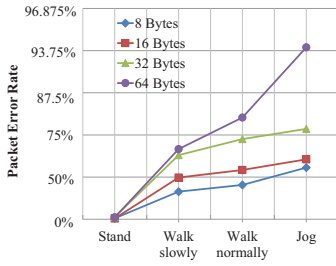

Fig. 6. Packet error rate for different sized packets under various speeds (y -axis in log scale).

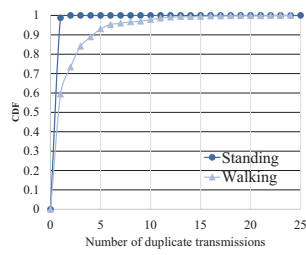

Fig. 7. CDF plot of duplicate transmission counts.

To get a basic idea, we do a measurement study with differently sized packets under four different scenarios, *i.e.*, standing still, walking slowly (0.5 Hz per foot), walking normally (1 Hz per foot), and jogging (1.5 – 2 Hz per foot). The results are shown in Figure 6. From Figure 6, we can learn that with increasing packet sizes and moving speeds, the packet error rate grows.

The second challenge owns to the unpredictable packet error rate. The error rate is subject to many factors, such as the speed of walking, stride length and ambient environment. When walking slowly with small stride length, the possibility of successful transmission is high; with increasing moving speed and stride length, the number of retransmissions required before successful transmission grows. Even the multipath effect from a passerby can create changes in signal amplitude, leading to decoding errors. Figure 7 shows the CDF plot of duplicate transmission counts for successfully transmitting a 16-byte packet under static scenario and moving scenario (*i.e.*, walking at a speed of 1 Hz per foot). In the walking scenario, for the majority of times, it requires at most 5 times of duplicate transmission. However, in the worst case, it requires more than 20 times of retransmissions. Traditional error control methods work by adding fixed ratio of redundancy in data transmission, which is unsuitable in this case where the error rate fluctuates significantly.

B. Rateless Transmission

From the challenges illustrated above, we identify two characteristics. The first one is that short packets are favorable, as the transmission time is short and thus human motion is unlikely to change the channel condition within the time span of a packet transmission (*e.g.*, 0.1s). The second challenge suggests that flexible adaptation to channel condition is highly beneficial [29].

To jointly tackle these two challenges, we borrow the idea from rateless codes. We divide the whole packet into k blocks of equal size. At each transmission, instead of transmitting a complete packet, we transmit a short sub-packet which is a combination of some of the k blocks. The transmitter continuously transmits sub-packets until the receiver has received enough number of sub-packets for decoding.

Moreover, we can further take advantage of the moving pattern of the two feet to design the transmission mechanism. Traditional rateless codes (*e.g.*, LT codes [23], raptor codes [27]) randomly select a subset of the k blocks to be combined into a sub-packet. When moving, two feet follow

a repetitive moving pattern. By exploiting this, we can design a transmission sequence that can reduce the number of transmissions.

When walking or running, two feet get far away when stepping out; within the swing phase, there is a short moment that the two feet are close to each other, during which there is high probability for successful transmission. Figure 8 illustrates this phenomenon. The upper line shows the packets that are correctly received, and the lower line shows the corrupted packets.

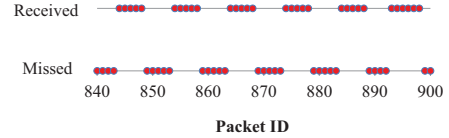

Fig. 8. Received packet sequence.

From Figure 8, we can learn that it is likely to correctly receive packets in a burst, which corresponds to the duration when the two feet are close. To fully take advantage of this short burst, it is favorable that the sub-packets transmitted within this burst are sufficient for decoding the original packet. In other words, when viewing each block as a variable and a sub-packet as a linear combination of these variables, the receiver needs k linearly independent sub-packets to recover the original packet. We would like to construct a series of linearly independent sub-packets, thus by receiving any k sub-packets can the receiver decode the original packet.

Although it is easy to construct linearly independent sub-packets, the transmitter has to indicate the coefficients for each variable (block). In this way, the overhead of header grows linearly with k , which is undesirable. To reduce the header overhead, we design a coefficient matrix, shown as follows:

$$\begin{pmatrix} \alpha_1^0 & \alpha_1 & \alpha_1^2 & \cdots & \alpha_1^{k-1} \\ \alpha_2^0 & \alpha_2 & \alpha_2^2 & \cdots & \alpha_2^{k-1} \\ & & \vdots & & \\ \alpha_n^0 & \alpha_n & \alpha_n^2 & \cdots & \alpha_n^{k-1} \end{pmatrix},$$

where $\alpha_1 = 0$ and $\alpha_i = \alpha_{i-1} + 1$, for any integer $i \in [2, n]$. We can prove that for any k out of the n row vectors, they are linearly independent.

Proof: Without loss of generality, we take the first k rows. They form a $k \times k$ matrix. The determinant of this square matrix is

$$\prod_{1 \leq i < j \leq k} (\alpha_j - \alpha_i).$$

From the fact that $\alpha_i \neq \alpha_j$ for $\forall i \neq j$, the determinant is non-zero. Thus, these k row vectors are linearly independent. It can be easily generalized that any k out of the n row vectors are linearly independent. ■

Thus, in the header, the transmitter only needs to indicate α_i when transmitting the i -th sub-packet. By receiving any k sub-packets, the receiver can decode the message.

VI. IMPLEMENTATION

We implement the prototype in a pair of sport shoes. Two 3-mm thick PVC plates are cut into the size and shape of

shoes' insole, such that they can be fit into the shoes. On each insole, there are two PZT bimorphs, as shown in Figure 4. The two PZT elements on each bimorph are connected together, forming one electrical polarity. The copper electrode between the two PZT elements forms another polarity.

The circuits are fabricated on a two-layer PCB. The buck converters are implemented using the LTC3588-1 from Linear Technology [5], with four selectable output voltages of 1.8V, 2.5V, 3.3V and 3.6V. Each bridge rectifier comprises of four 1N5819 Schottky diodes. We use ZXMN2F30FH n-channel MOSFETs as power switches, to prevent the loads from draining the harvested energy before the storage capacitors have built up enough energy. The PGOOD pin from LTC3588-1 serves as the indicator for turning on/off the power switch.

We use the EFM32ZG110 [3] as the micro-controller, which is an ultra-low power 32-bit ARM Cortex-M0+ processor running up to 24MHz. It has 4kB RAM and 32kB flash memory. It consumes only $0.9\mu A$ in deep sleep mode. To demonstrate the system as a pedometer, we select the accelerometer ADXL362 from Texas Instruments as the sensor. The accelerometer is configured to 2g measurement range with a sampling frequency of 25Hz. The accelerometer has a deep 512-sample FIFO buffer, thus the micro-controller only needs to wake up periodically to get the 3-axis acceleration data via SPI. On the other foot, the DA14580 [2] Bluetooth Smart Soc communicates with the micro-controller via USART. We develop an Andriod app to receive and display data transmitted from DA14580. The app runs on a Samsung Galaxy S4 smartphone with Andriod 4.4.2. The storage capacitor for the micro-controller, accelerometer, Bluetooth are 47uF, 22uF and 330uF, respectively. Their supplying voltages are set to be 2.5V, 1.8V, 3.3V.

The ambient backscatter module is implemented as in [21], using the parameters for 1 kbps data rate. The antenna is tuned for 900MHz. We use a USRP N210 [12] to continuously generate 900MHz ambient signals. Although the prototype can be tested with TV signals, we use USRP for it is easier to run controlled benchmark evaluation. Figure 9 shows our prototype.

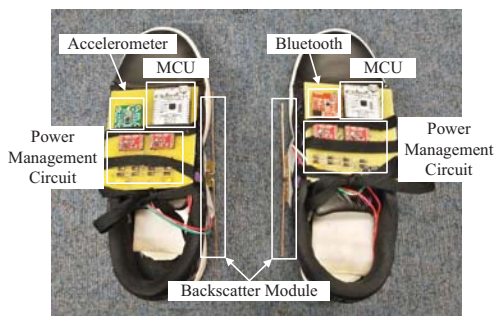

Fig. 9. Pictures of our prototype.

VII. EVALUATION

We evaluate the system from the aspects illustrated in Section III-A.

A. System Start-up and Brownout Time

In our scenario, our energy source is only intermittently available when the user is walking or running. It is preferred

that our system can start up shortly after the user starts moving around. It is also preferred that the system can sustain for a period after the user rests, so as to prevent frequent brownout of micro-controllers.

As we mentioned before, the voltage on the input storage capacitor has to accumulate above a certain threshold to wake up the buck converter. Thus, there is a gap between the time when the user starts walking and the time when the system wakes up. We name this gap as start-up time. Contrary to start-up time, the system can sustain for a short period after the user stops stepping, for the voltage on the input storage capacitor is above the shunt off threshold of buck converter. The system will brownout when the voltage drops below the threshold. We name this period as brownout time.

We invite five volunteers to participate in the experiments. They are all college graduate students, one female and four male (BMI: 20, 20.8, 21.9, 22.9, 31). For each volunteer, we put the energy harvesting insoles into his/her own shoes, and also attach the circuits to the shoes (as shown in Figure 9). They are instructed to walk at their preferred walking speed. Initially, there is no charge on the input capacitors. The results are shown in Table II. The results for each volunteer are averaged over five runs of experiments.

TABLE II
SYSTEM START-UP/BROWNOUT TIME.

Experiment Number	Start-up Time (sec)	Brownout Time (sec)
1	6.0	13.8
2	7.6	22.2
3	9.0	17.2
4	5.4	25.0
5	6.6	28.8

From Table II, we can learn that the system can start-up shortly after the user starts walking. In our experiments, it takes 5 – 9 seconds' walking to wake up the system. We expect this period to be even shorter in practical use, for it is very likely that the input capacitors have some initial charge, which is the residual energy from the last walking period. The system can sustain for at least 13 seconds after the user rests, which can prevent the micro-controller from being powered-off frequently when the user comes to a short pause, such as stops to open the door, or encounters a friend and pauses for a short conversation. For micro-controllers consume tiny power in sleep mode (*e.g.*, $0.9\mu A$ for EFM32ZG in deep sleep mode), it is reasonable that it can sustain for short periods when there is no energy source.

Besides accelerometers, when integrated with other sensors, we expect the micro-controller can also have short start-up time and sufficient brownout time, as micro-controllers follow the similar duty-cycle. For the majority of time, micro-controllers are in deep sleep mode, and only wake up periodically to get sensor readings and process sensor data.

B. Bluetooth Throughput and Transmission Frequency

Bluetooth throughput measures how many and how frequently data can be transmitted from our shoes to users' smartphone. In this subsection, we evaluate how many bytes can be transmitted by Bluetooth during walking (1 Hz per foot) and jogging (1 – 2 Hz per foot) periods. There is no charge on both capacitors at the beginning of each experiment.

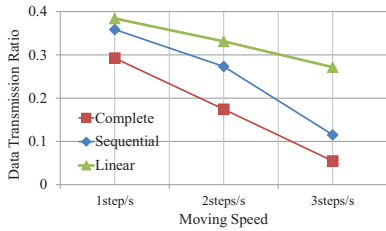

Fig. 10. Different moving speeds.

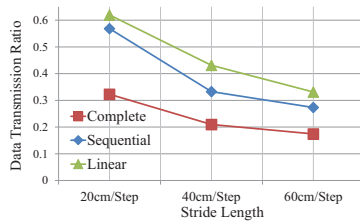

Fig. 11. Different stride lengths.

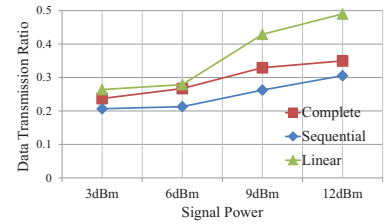

Fig. 12. Different signal power.

Bluetooth consumes much more power than the micro-controller and accelerometer. To save energy, it is powered off for the majority of time, and only wakes up periodically to transmit data. When the input capacitor for Bluetooth (*i.e.*, C_2) has accumulated enough energy, it will signal an interrupt to the micro-controller. The micro-controller will turn on the power switch to power on Bluetooth and wait for connection with smartphone. When connected, Bluetooth will continuously transmit data to the smartphone until the voltage on C_2 drops below the shunt off threshold of buck converter. The results are shown in Table III.

On average, during walking, Bluetooth can transmit about 48-byte data per minute. The first transmission starts after 1.5 minutes' walking. During jogging, it can transmit about 60 bytes every 48 seconds. The first transmission starts after 1 minute on average.

TABLE III
BLUETOOTH THROUGHPUT.

	No.	Duration	Throughput	First Transmission Time
Walking	1	10min	489 bytes	56sec
	2	10min	426 bytes	1min 40sec
	3	10min	535 bytes	1min 14sec
	4	11min	492 bytes	2min 0sec
	5	11min	541 bytes	1min 21sec
Jogging	1	8min	610 bytes	38sec
	2	10min	535 bytes	1min 1sec
	3	10min	856 bytes	1min 44sec
	4	10min	718 bytes	1min 23sec
	5	10min	901 bytes	53sec

The system is suitable for applications which do not require always-on Bluetooth connection and only need to update information periodically. For applications such as pedometer and heart rate monitor, it is sufficient to synchronize with the smartphone once per minute. 48–60-byte per minute throughput is adequate for carrying information about timestamps and step counts/heart rate.

C. Performance on Rateless Transmission

In this subsection, we show the evaluation results on rateless transmission. From Figure 6, we can learn that the packet error rates are very high for 32-byte case and 64-byte case when moving fast. Although 8-byte case performs better than the 16-byte case, there is a trade-off between packet size and the overheads of preambles and headers. In our implementation, we use sub-packets with 16-byte data.

We compare our design with two other mechanisms: directly transmit a complete packet with 64-byte data (*i.e.*, complete transmission); and divide the original packet into

4 sub-packets, each with 16-byte data, and transmit the sub-packets sequentially (*i.e.*, sequential transmission). We name our mechanism as linear transmission. We use the data transmission ratio (DTR) as the benchmark, which is defined as

$$DTR = \frac{D_{rx}}{T_{tx}},$$

where T_{tx} is the total amount transmitted by the transmitter, including data, headers and CRC, and D_{rx} is the amount of valid data correctly received by the receiver, excluding headers and CRC.

We vary four testing parameters, including moving speed, stride length, signal power, and testing environment. For each combination of parameters, we test each mechanism for 10 minutes.

1) *Moving Speed*: Figure 10 shows the results under different moving speeds. The default stride length is 60cm. When moving at a speed of 0.5Hz per foot, the results for three mechanisms are close; with increasing moving speeds, the Linear mechanism outperforms the other two, for our mechanism is specially designed according to the moving pattern of walking. On average, the Linear mechanism outperforms the Complete and Sequential mechanism by 89% and 32%, respectively.

2) *Stride Length*: Figure 11 shows the results under different stride lengths. The default moving speed is 1 Hz per foot. With small stride length, short packets can be correctly received, but long packets suffer high packet error rate, since they require longer transmission time. Thus, both Linear and Sequential mechanisms perform better than Complete mechanism. All the performance drop with increasing stride length, for the distance between the transmitter and the receiver increases. On average, the Linear mechanism outperforms the Complete and Sequential mechanism by 96% and 18%, respectively.

3) *Signal Power*: Figure 12 shows the results for different signal power. The bandwidth of USRP is set to 6MHz, which is the bandwidth of TV channel. we measure the signal power at the transmitter's side, using Rohde & Schwarz spectrum analyzer with a VERT900 antenna. The default moving speed and stride length are 1 Hz per foot and 60cm, respectively. In this figure, it is counterintuitive that Complete performs better than Sequential mechanism and very close to Linear when the signal power is 3dBm and 6dBm. Although sub-packets have lower error rates, but they also have higher overheads. When we only consider data transmission ratio, it is possible that Complete performs better than Sequential. On average, the Linear mechanism outperforms the Complete and Sequential mechanism by 24% and 48%, respectively.

4) *Testing Environment*: We test the three mechanisms in three different environments, an office cubicle, an empty

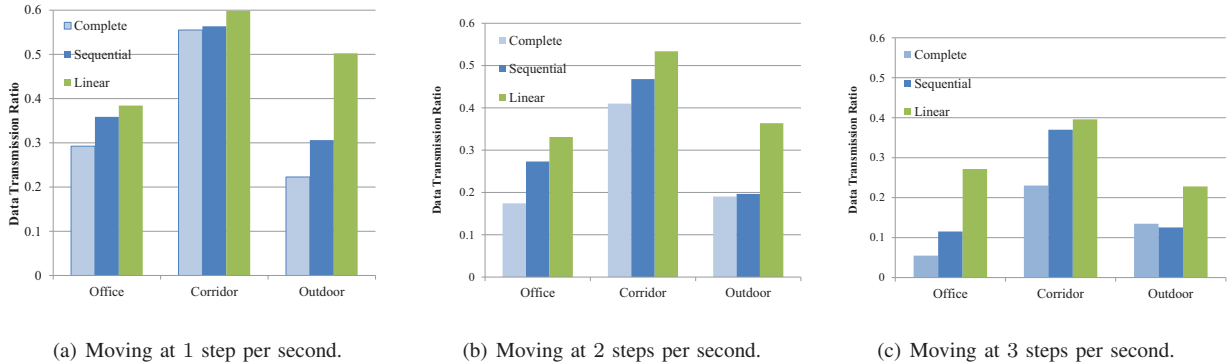

Fig. 13. Data transmission ratios in three different environments.

corridor outside the office and an outdoor open ground in the campus. We test with three different moving speeds and the results are shown in Figure 13.

In general, the performance is best in the corridor, for the experiments are conducted in a public holiday and there are few people passing by the corridor. Different from the corridor, inside the office, there are a lot of objects and equipments that may reflect the ambient signals, making the multipath profile much more complicated than the empty corridor. In the open ground, the performance is susceptible to the nearby environment. When there are passengers walking by, it would cause interference to the transmission.

With increasing speeds, the overall performance of the three mechanisms drop. From Figure 13, it is clear that Linear mechanism performs better than the other two when the environment is poor (*i.e.*, in the outdoor scenario), which demonstrates that our mechanism is more robust under different environments.

VIII. DISCUSSION

In this section, we discuss some practical issues.

Start-up delays. We demonstrate our platform with an accelerometer. There is a start-up delay, where the users have to walk several steps before the accelerometer can start sensing. For some applications that need to accurately count the number of steps taken, such as the pedometer, the results can be calibrated to improve accuracy. For example, for each walking or running period, the actual step counts are the number we get from the accelerometer plus some small constants (*e.g.*, 3, 4, 5), which may be user dependent.

Compatible applications. We demonstrate our sensing platform as a pedometer. According to the requirement illustrated in Section III-A, our sensing platform can support many other sensors. Take pulse sensor for an example. First, toe is an appropriate place to measure heart rate with PPG sensor. Second, although the energy harvesting module may not support instantaneous heart rate monitoring, it can measure heart rate periodically, say once per minute, which is sufficient for daily health tracking. Last, as in many commercial heart rate monitor [7], we only need to send the heart rate information to smartphone, not the snippets of heart signal, the 48 – 60-byte Bluetooth throughput is sufficient to include both timestamps and heart rate information. Other appropriate sensors may be temperature sensor, ultrasonic sensor for obstacle detection, etc.

Rateless transmission We use rateless transmission to tackle the fluctuating error rate during ambient backscatter. Although backscatter communications work the best when two feet are close to each other and the walking/running cycles are easy to detect using IMU (inertial measurement unit) sensors, the sensing and processing may consume extra energy for applications other than pedometer. Furthermore, ambient backscatter consumes nearly zero energy, hence continuous transmission is still more energy efficient compared with BLE/Zigbee. Although the throughput of ambient backscatter is low, it is sufficient to transmit control message and data between two feet. Thus, it is suitable to serve as a data channel in such a low power platform.

Energy source unavailable when resting Our platform is targeted for applications that are functioning only when the user is moving. The energy source is unavailable when the user is not moving around. To compensate for this, we may combine multi-modal energy harvesting, such as harvesting the energy from human breathing, heart beat and body heat, which are constantly available.

IX. RELATED WORKS

A. Energy Harvesting Shoes

By means of energy generation, existing works on energy harvesting shoes can be generally classified into two categories: shoe-mounted electromagnetic generator and piezoelectric shoes. Electromagnetic generator is a well-proven technology to transform mechanical energy to electrical energy, which is widely used in electric power grids. However, the solid mechanical generator is usually heavy and cumbersome, which makes it hard to be integrated into shoes unobtrusively. An alternative approach is to use piezoelectric materials. Piezoelectric materials can generate electric charge in response to applied mechanical stress. The prototype designed in [19] shows that we can get 1.1 mW from PVDF stave and 1.8 mW from PZT Unimorph. In a recent study [33], the authors consider both the performance and durability of the PVDF, and designed a sandwiched structure. Their harvester provides about 1 mJ per step. Compared with electromagnetic generator, the energy conversion efficiency is two orders of magnitude lower. However, piezoelectric materials are lightweight and can be easily incorporated into an insole structure.

In our experiments, for different subjects, our energy harvesting insole can generate about 1 – 2 mW per step, which is comparable to existing works.

B. Ambient Backscatter Communication

Liu *et al.* [21] first proposed ambient backscatter communication, which does not need a powerful reader to generate continuous carrier wave. Instead, it directly modulates the ubiquitous TV signals in the air. They demonstrated that their prototype can communicate up to 2.5 feet without any dedicated reader, only by energy harvesting from ambient RF signals. Parks *et al.* [24] designed multi-antenna cancellation techniques and a low power coding scheme for ambient backscatter, using only analog components without any digital computation. They significantly improved the communication rate and distance of ambient backscatter. Liu *et al.* [22] enables full-duplex ambient backscatter, which gives a way for the receiver to provide instantaneous feedback to the transmitter. Both the transmitter and receiver consume less than 1 μ W.

Based on existing works on ambient backscatter, we design a rateless transmission mechanism that is suitable for data transmission between two feet in motion. Experiment results show that our mechanism is robust under different scenarios.

C. Ultra-low Power Sensing Platform

There are a lot of research efforts devoted to designing ultra-low power sensing platform. WISP [25] is an RFID-based sensing platform. Based on WISP, researchers made improvement to provide more code space and RAM, and reduce energy consumption [30]. Zhang *et al.* [31] identified that given the low-power backscatter communication and ultra low-power sensor modalities, energy consumption for computation is the bottleneck. EkhoNet focuses on reducing the power consumption in the computation pipeline and transfers raw sensor data by backscattering. Thus, they reduce the end-to-end energy consumption to tens of μ W. Lee *et al.* [20] proposed a mm^3 scale general-purpose sensor node platform. It has an optical receiver for optical communication.

Different from existing works, we propose a battery-free sensing platform for wearable devices. In our scenario, we cannot rely on any dedicated powerful reader. Although there is the possibility for our smartphones to serve as the reader, it would largely shorten phones' battery runtime. Furthermore, different from wireless sensing nodes, wearable devices should communicate directly with commercial smartphones for data analysis and synthesis. The most popular communication protocols are WiFi, Bluetooth or ANT+, all of which consume much more energy than backscatter communication. Thus, existing ultra-low power sensing platforms are not suitable for wearable computing.

X. CONCLUSION

In this study, we have designed a battery-free platform for wearable devices in the form-factor of shoes. The platform runs solely on the harvested energy from human walking or running. It supports sensing, processing and wireless communication with smartphone, covering all the functionality of commercial wearable devices. We have achieved this goal by combining the harvestable energy from two feet. Each foot performs separate tasks and two feet are coordinated by ambient backscatter. Considering the motion pattern of human feet, we have designed a rateless transmission mechanism to improve the overall throughput and reduce overhead in data transmission. We have implemented a prototype to demonstrate the feasibility of our idea. Evaluation results show that our design is robust enough for practical use. We believe

that our framework will foster a lot of interesting applications which were previously impossible.

ACKNOWLEDGMENT

The research was supported in part by grants from 973 project 2013CB329006, RGC under the contracts CERGMHKUST609/13 and 622613, China NSFC under Grant 61502114, ITS/143/14FP-A.

REFERENCES

- [1] "CC2630," <http://www.ti.com/product/cc2630>.
- [2] "DA14580," <http://www.dialog-semiconductor.com/products/bluetooth-smart/smartbond-da14580>.
- [3] "EFM32," <http://www.silabs.com/products/mcu/32-bit/efm32-gecko/Pages/efm32-gecko.aspx>.
- [4] "Lechal," <http://lechal.com/>.
- [5] "LTC3588," <http://www.linear.com/product/LTC3588-1>.
- [6] "MAX21100," <http://www.maximintegrated.com>.
- [7] "Mio," http://www.mioglobal.com/product_info.htm.
- [8] "MSP430," http://www.ti.com/lscs/ti/microcontrollers_16-bit_32-bit/msp/ultra-low_power/overview.page.
- [9] "Nike+," <https://secure-nikeplus.nike.com/plus/>.
- [10] "nLink RS9110-n-11-02," <http://www.redpinesignals.com/Modules/>.
- [11] "Pulse sensor," <http://pulsesensor.com/>.
- [12] "USRP N210," <http://www.ettus.com/product/details/UN210-KIT>.
- [13] S. Gollakota, M. S. Reynolds, J. R. Smith, and D. J. Wetherall, "The emergence of RF-powered computing," *Computer*, vol. 47, no. 1, pp. 32–39, 2014.
- [14] M. Gorlatova, J. Sarik, G. Grebla, M. Cong, I. Kymissis, and G. Zussman, "Movers and shakers: Kinetic energy harvesting for the internet of things," in *Proc. SIGMETRICS 2014*.
- [15] K. Ha, Z. Chen, W. Hu, W. Richter, P. Pillai, and M. Satyanarayanan, "Towards wearable cognitive assistance," in *Proc. MobiSys 2014*.
- [16] D. Han and V. Kaajakari, "Microstructured polymer for shoe power generation," in *Proc. Transducers 2009*.
- [17] S. Jain, C. Borgiattino, Y. Ren, M. Gruteser, Y. Chen, and C.-F. Chiasserini, "Lookup: Enabling pedestrian safety services via shoe sensing," in *Proc. MobiSys 2014*.
- [18] B. Kellogg, V. Talla, and S. Gollakota, "Bringing gesture recognition to all devices," in *Proc. NSDI 2014*.
- [19] J. Kymissis, C. Kendall, J. Paradiso, and N. Gershenfeld, "Parasitic power harvesting in shoes," in *Proc. ISWC 1998*.
- [20] Y. Lee, G. Kim, S. Bang, Y. Kim, I. Lee, P. Dutta, D. Sylvester, and D. Blaauw, "A modular 1mm³ die-stacked sensing platform with optical communication and multi-modal energy harvesting," in *Proc. ISSCC 2012*.
- [21] V. Liu, A. Parks, V. Talla, S. Gollakota, D. Wetherall, and J. R. Smith, "Ambient backscatter: wireless communication out of thin air," in *Proc. SIGCOMM 2013*.
- [22] V. Liu, V. Talla, and S. Gollakota, "Enabling instantaneous feedback with full-duplex backscatter," in *Proc. MobiCom 2014*.
- [23] M. Luby, "LT codes," in *Proc. FOCS 2002*.
- [24] A. N. Parks, A. Liu, S. Gollakota, and J. R. Smith, "Turbocharging ambient backscatter communication," in *Proc. SIGCOMM 2014*.
- [25] A. P. Sample, D. J. Yeager, P. S. Powlledge, A. V. Mamishev, and J. R. Smith, "Design of an rfid-based battery-free programmable sensing platform," *IEEE Transactions on Instrumentation and Measurement*, vol. 57, no. 11, pp. 2608–2615, 2008.
- [26] N. S. Shenck and J. A. Paradiso, "Energy scavenging with shoe-mounted piezoelectrics," *IEEE micro*, vol. 21, no. 3, pp. 30–42, 2001.
- [27] A. Shokrollahi, "Raptor codes," *IEEE Transactions on Information Theory*, vol. 52, no. 6, pp. 2551–2567, 2006.
- [28] C. Wang, M. Osada, Y. Ebina, B.-W. Li, K. Akatsuka, K. Fukuda, W. Sugimoto, R. Ma, and T. Sasaki, "All-nanosheet ultrathin capacitors assembled layer-by-layer via solution-based processes," *ACS nano*, vol. 8, no. 3, pp. 2658–2666, 2014.
- [29] G. Wang, S. Zhang, K. Wu, Q. Zhang, and L. Ni, "TiM: Fine-grained rate adaptation in WLANs," *IEEE Transactions on Mobile Computing*.
- [30] H. Zhang, J. Gummeson, B. Ransford, and K. Fu, "Moo: A batteryless computational rfid and sensing platform," Tech. Rep. UM-CS-2011-020, 2011.
- [31] P. Zhang, P. Hu, V. Pasikanti, and D. Ganesan, "EkhoNet: high speed ultra low-power backscatter for next generation sensors," in *Proc. MobiCom 2014*.
- [32] C. Zhao, S. Yisrael, J. R. Smith, and S. N. Patel, "Powering wireless sensor nodes with ambient temperature changes," in *Proc. UbiComp 2014*.
- [33] J. Zhao and Z. You, "A shoe-embedded piezoelectric energy harvester for wearable sensors," *Sensors*, vol. 14, no. 7, pp. 12497–12510, 2014.